

Überbauung Roost, Zug

Haus B, Fridbachweg 5,7,9

Erdgeschoss: Wohnung Nr. 0503

4 1/2 - Zimmer, Nettogeschossfläche 110.25 m²

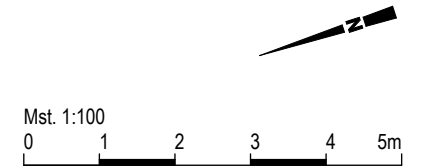
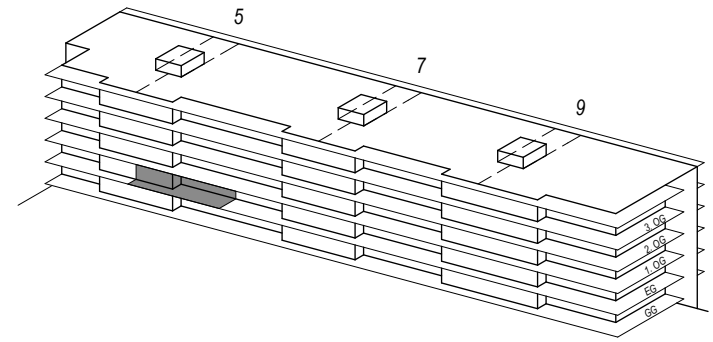
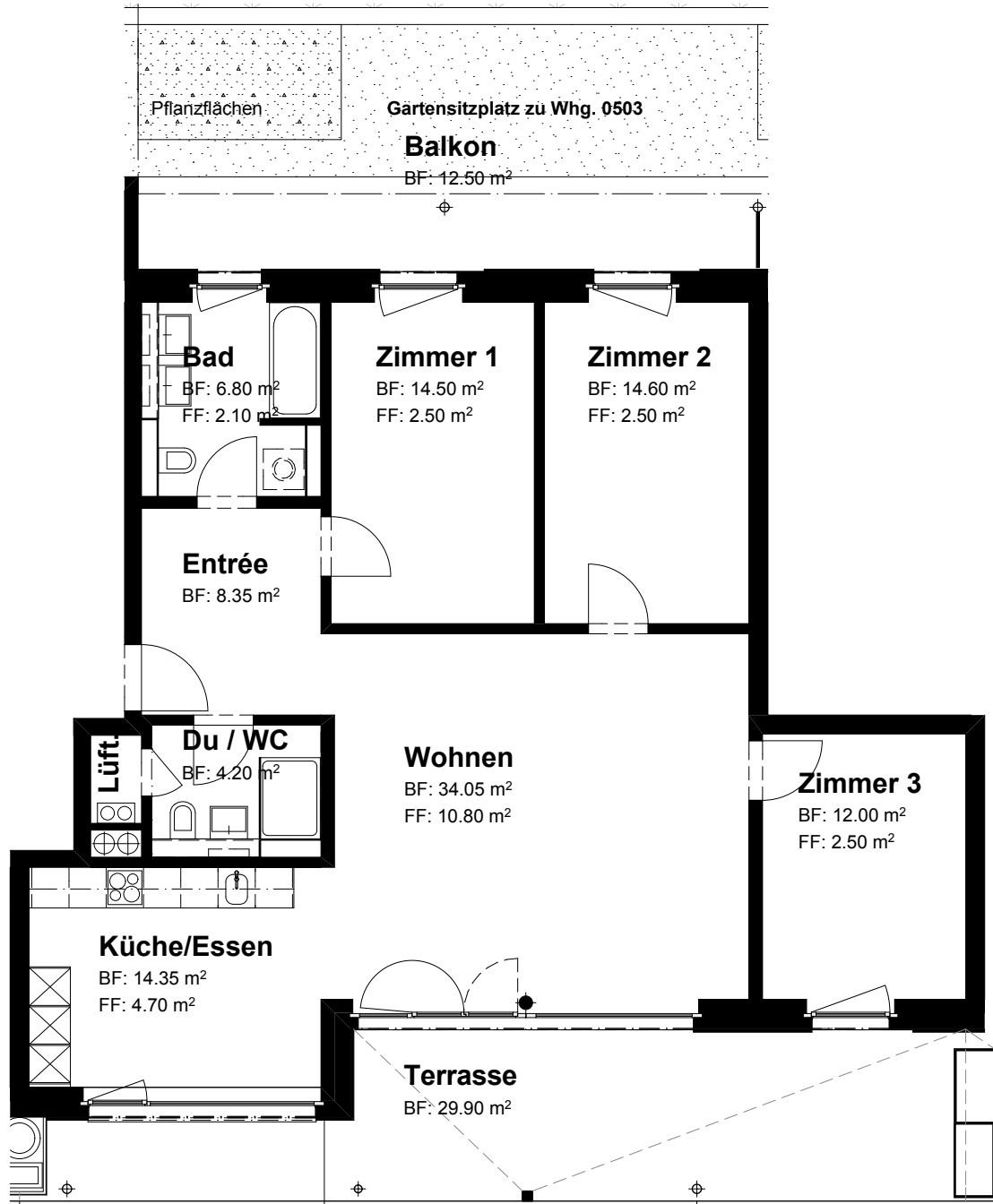

hwpARCHITEKTEN AG

Architekten ETH FH SIA
Chamerstr. 44 6331 Hünenberg
t 041 854 70 70 f 041 854 70 60
info@hwp.ch www.hwp.ch

Überbauung Roost, Zug

Haus B, Fridbachweg 5,7,9

1. Obergeschoss: Wohnung Nr. 0505

4 1/2 - Zimmer, Nettogeschossfläche 110.60 m²

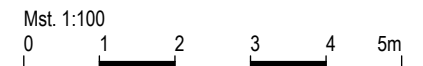
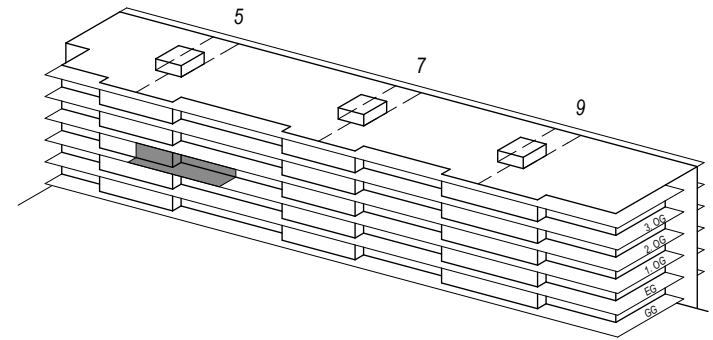
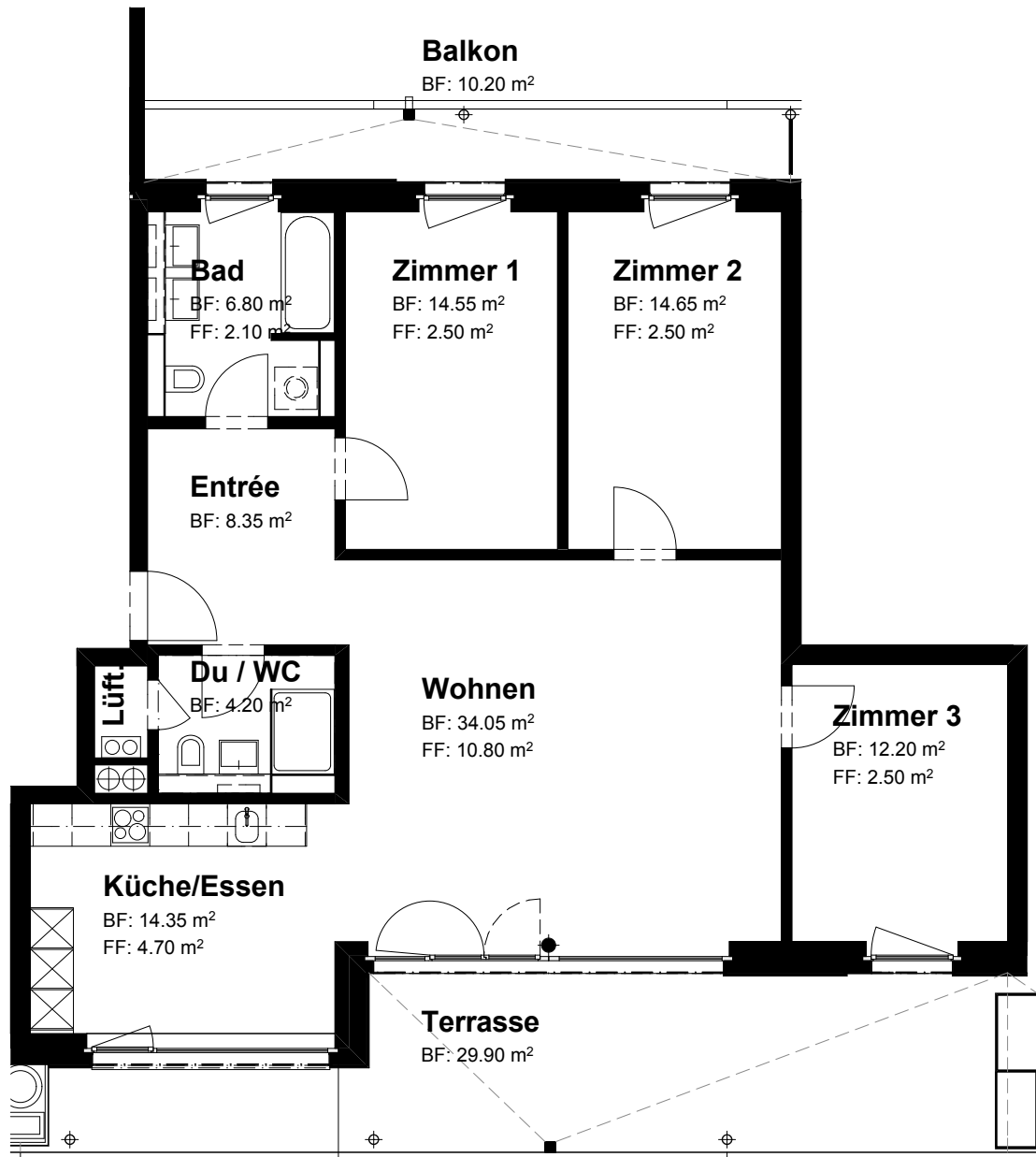

hwpARCHITEKTEN AG

Architekten ETH FH SIA
Chamerstr. 44 6331 Hünenberg
t 041 854 70 70 f 041 854 70 60
info@hwp.ch www.hwp.ch

Überbauung Roost, Zug

Haus B, Fridbachweg 5,7,9

2. Obergeschoss: Wohnung Nr. 0507

4 1/2 - Zimmer, Nettogeschossfläche 110.60 m²

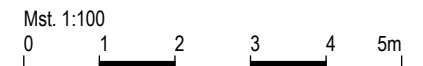
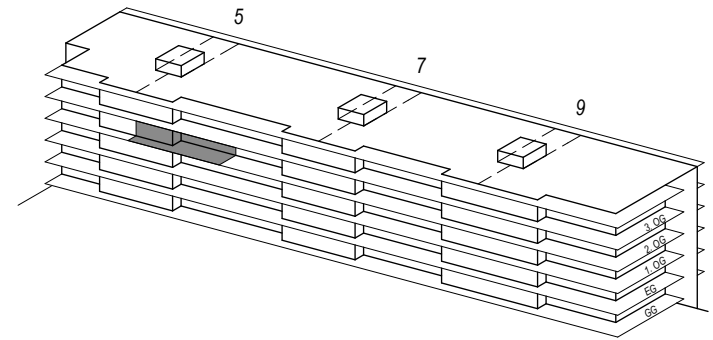
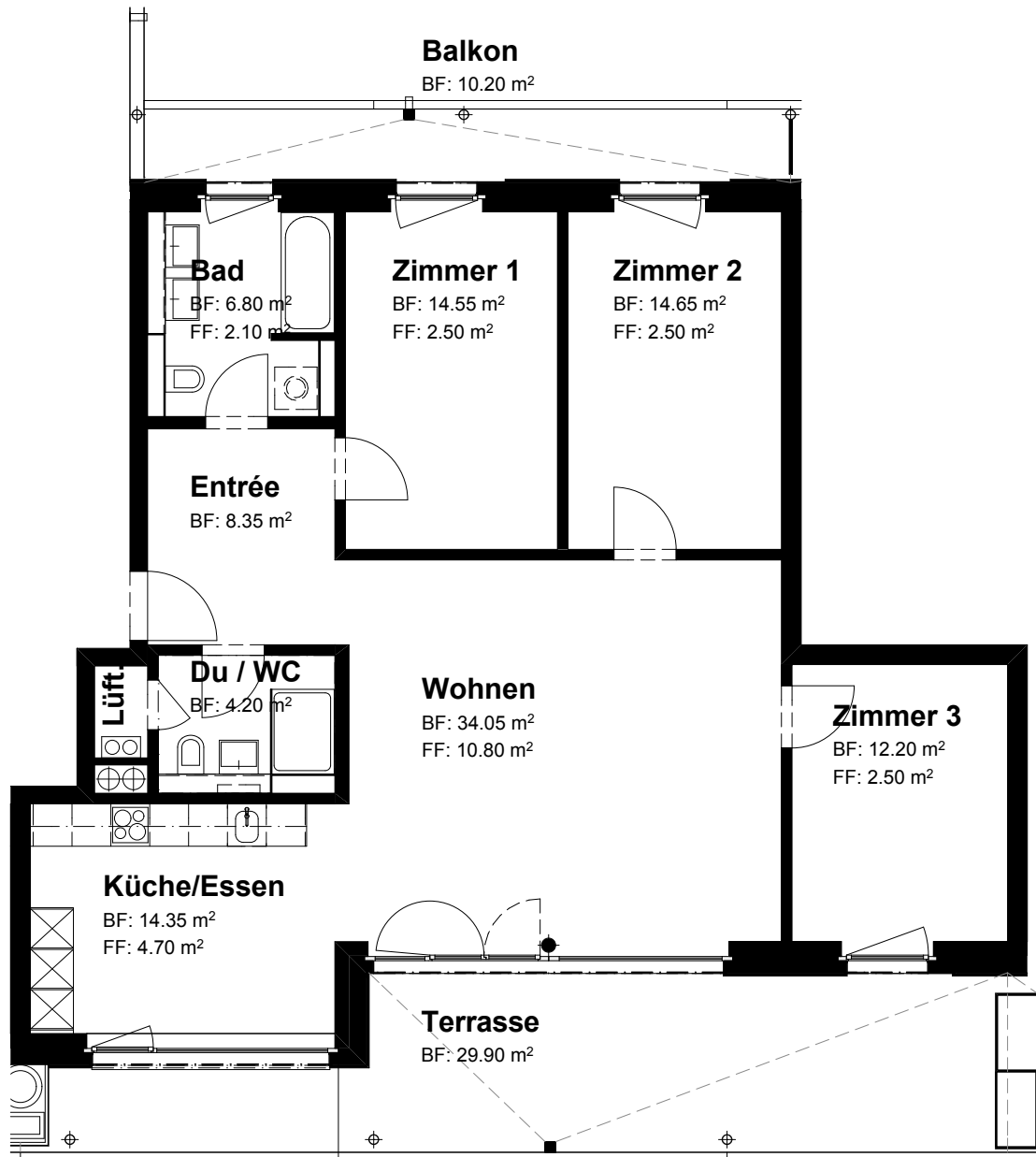

hwpARCHITEKTEN AG

Architekten ETH FH SIA
Chamerstr. 44 6331 Hünenberg
t 041 854 70 70 f 041 854 70 60
info@hwp.ch www.hwp.ch

Überbauung Roost, Zug

Haus B, Fridbachweg 5,7,9

Dachgeschoss: Wohnung Nr. 0509

4 1/2 - Zimmer, Nettogeschossfläche 110.70 m²

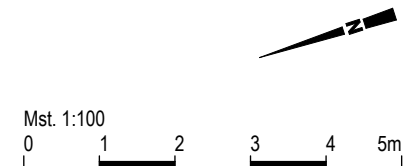
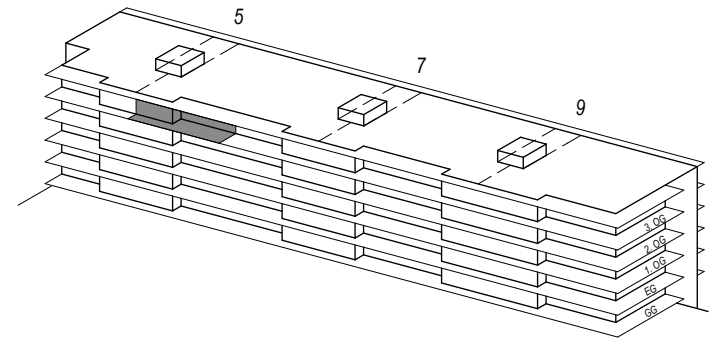

hwpARCHITEKTEN AG

Architekten ETH FH SIA
Chamerstr. 44 6331 Hünenberg
t 041 854 70 70 f 041 854 70 60
info@hwp.ch www.hwp.ch