

# Überbauung Roost, Zug

Haus B, Fridbachweg 5,7,9

Erdgeschoss: Wohnung Nr. 0504

4 1/2 - Zimmer, Nettogeschossfläche 117.30 m<sup>2</sup>

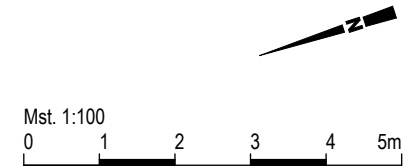
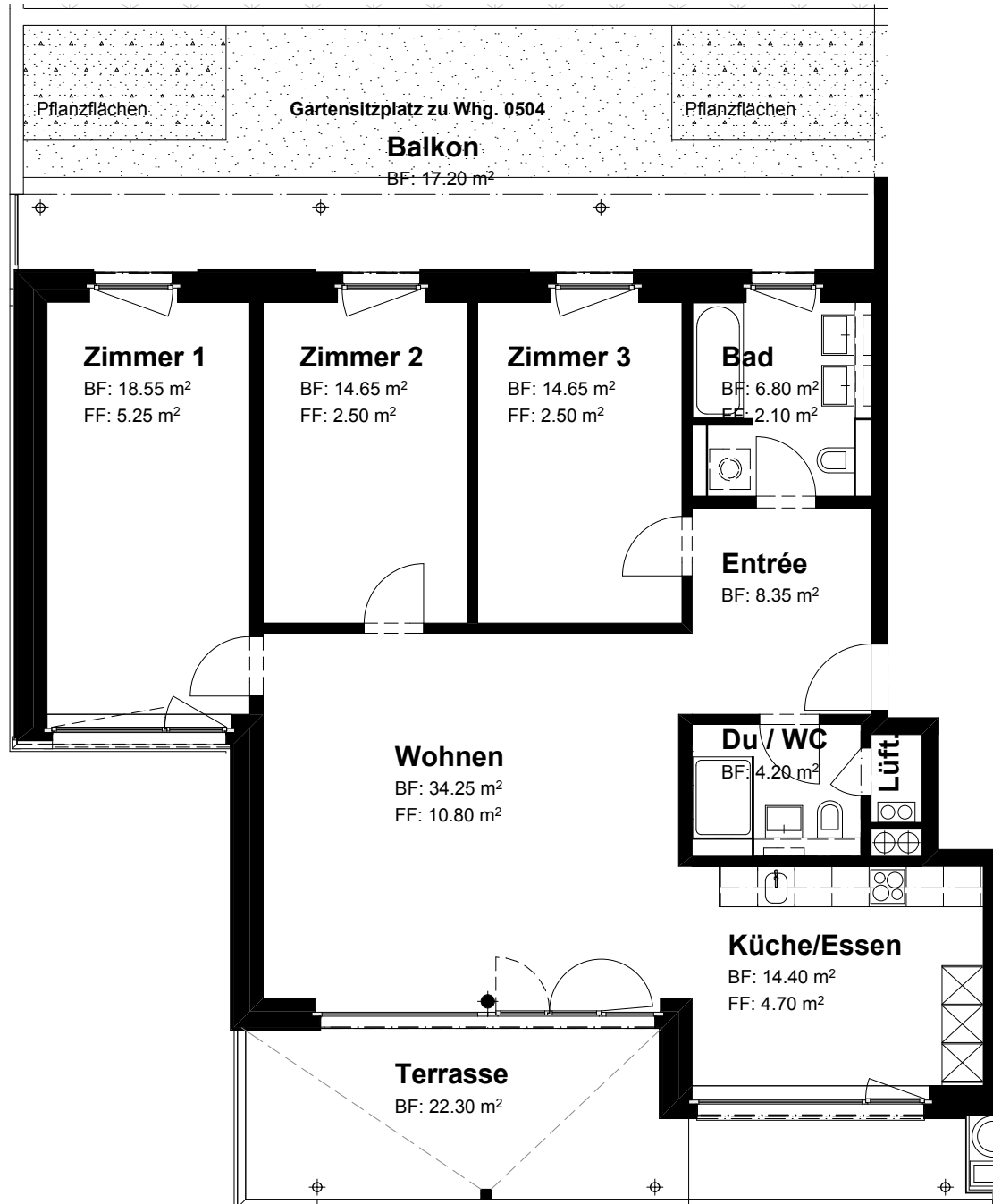
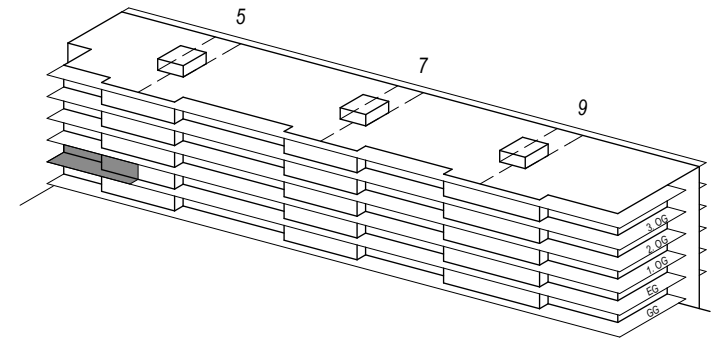

**hwp**ARCHITEKTEN AG

Architekten ETH FH SIA  
Chamerstr. 44 6331 Hünenberg  
t 041 854 70 70 f 041 854 70 60  
info@hwp.ch www.hwp.ch

# Überbauung Roost, Zug

Haus B, Fridbachweg 5,7,9

1. Obergeschoss: Wohnung Nr. 0506

4 1/2 Zimmer, Nettogeschossfläche 117.70 m<sup>2</sup>

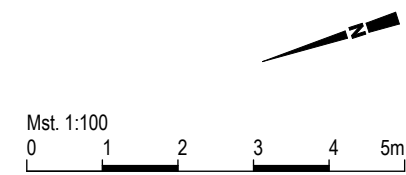
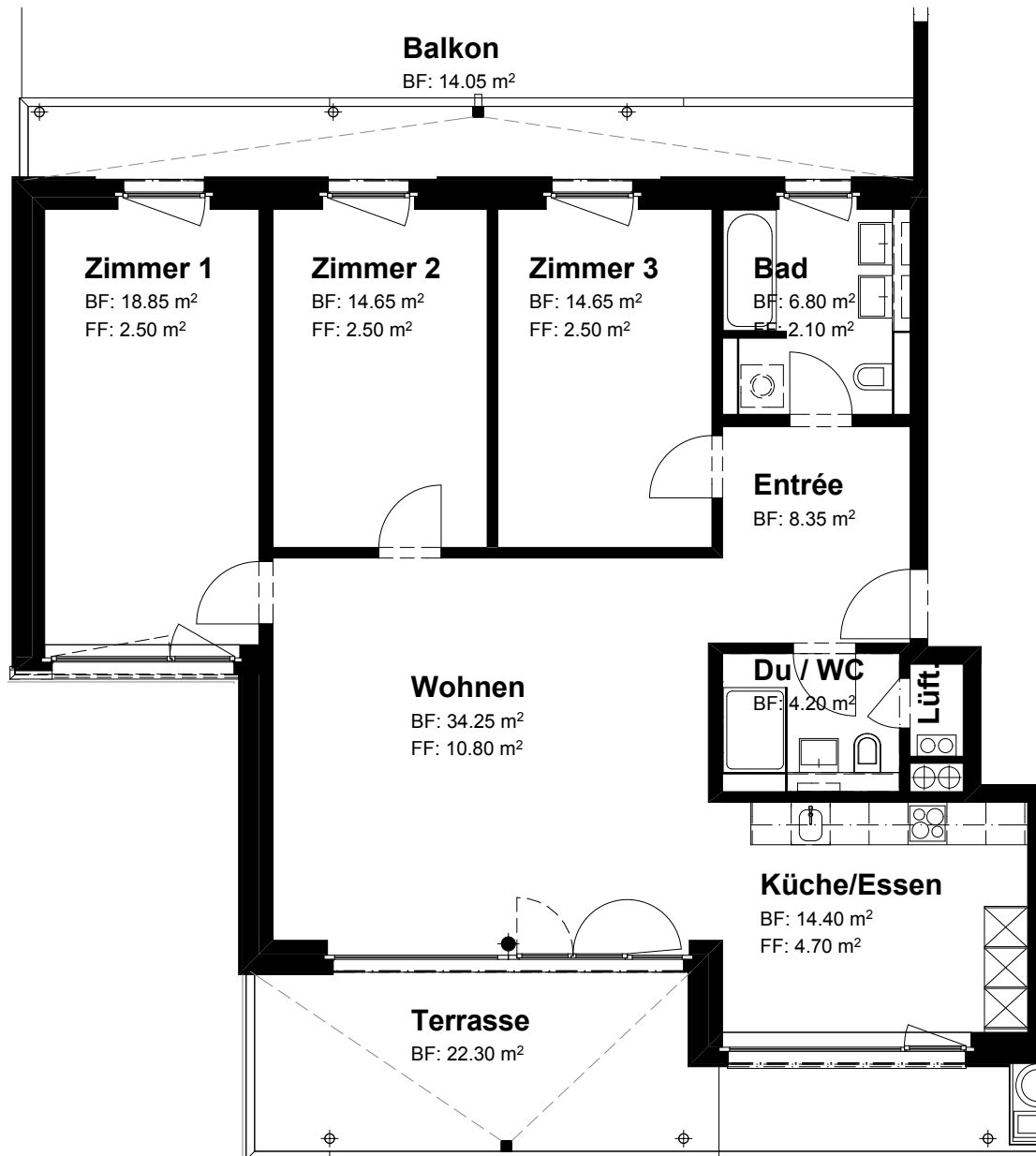
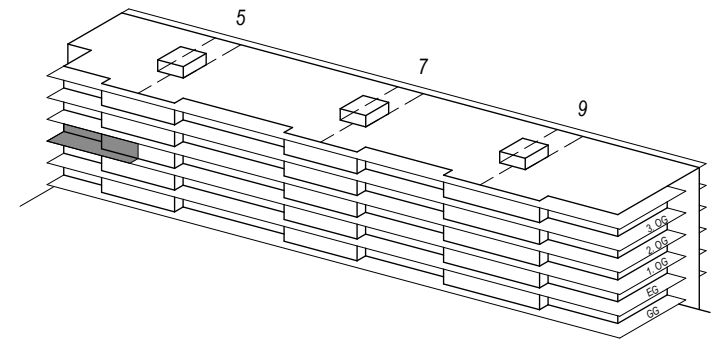

**hwp**ARCHITEKTEN AG  
Architekten ETH FH SIA  
Chamerstr. 44 6331 Hünenberg  
t 041 854 70 70 f 041 854 70 60  
info@hwp.ch www.hwp.ch

# Überbauung Roost, Zug

Haus B, Fridbachweg 5,7,9

2. Obergeschoss: Wohnung Nr. 0508

4 1/2 Zimmer, Nettogeschossfläche 118.10 m<sup>2</sup>

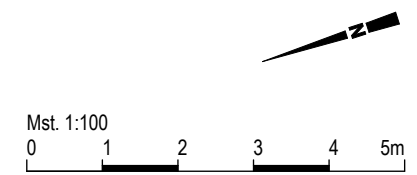
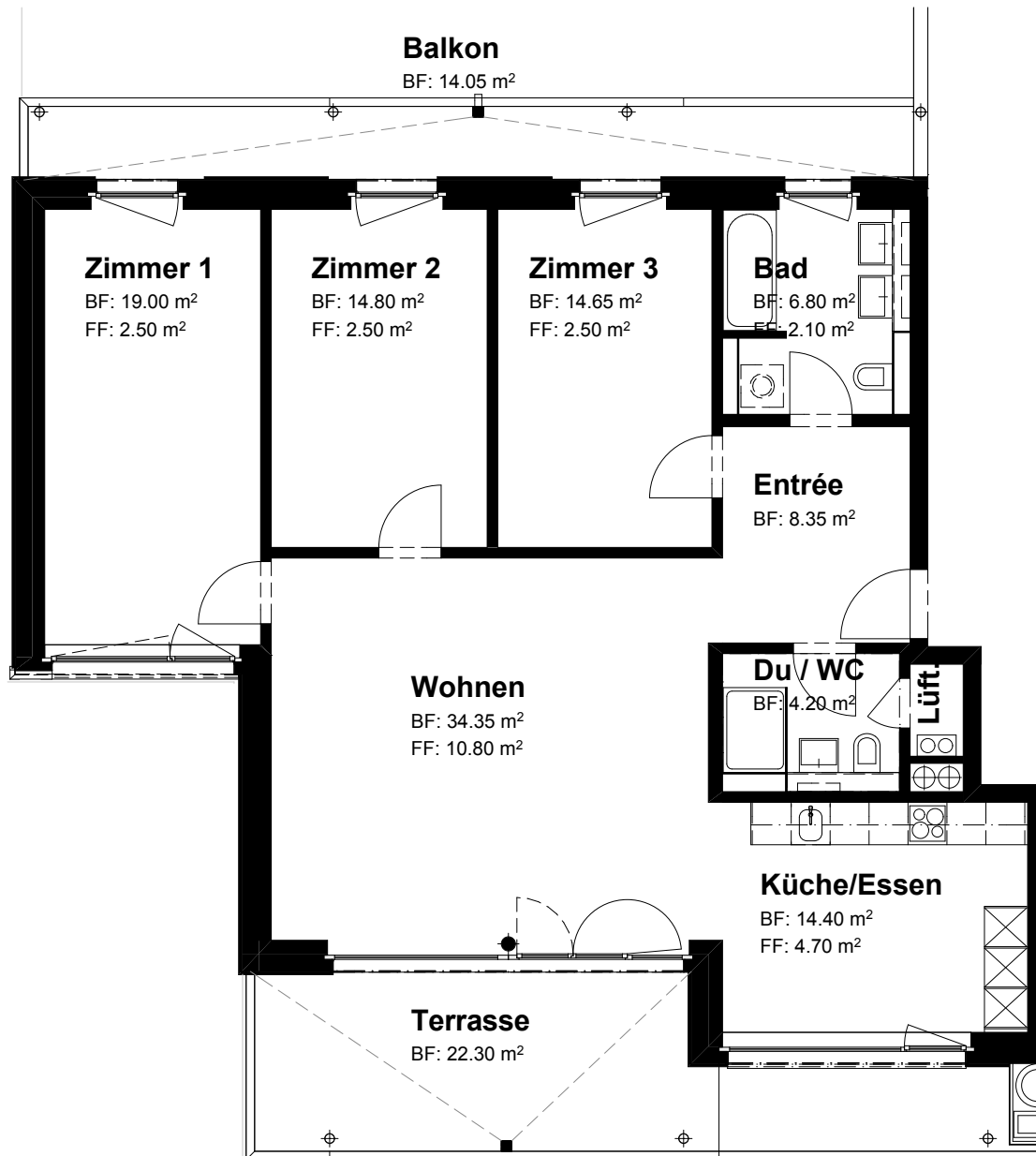
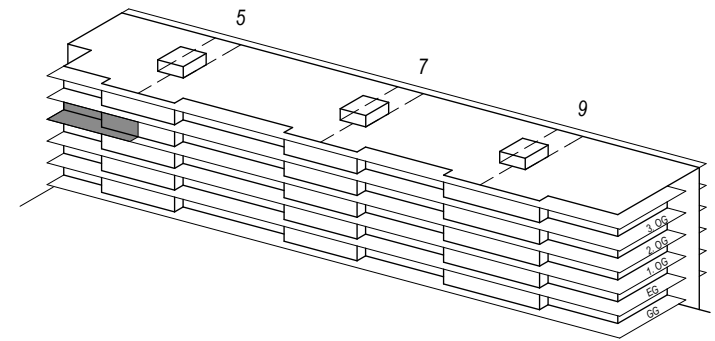

**hwp**ARCHITEKTEN AG

Architekten ETH FH SIA  
Chamerstr. 44 6331 Hünenberg  
t 041 854 70 70 f 041 854 70 60  
info@hwp.ch www.hwp.ch

# Überbauung Roost, Zug

Haus B, Fridbachweg 5,7,9

Dachgeschoss: Wohnung Nr. 0510

4 1/2 Zimmer, Nettogeschossfläche 118.25 m<sup>2</sup>

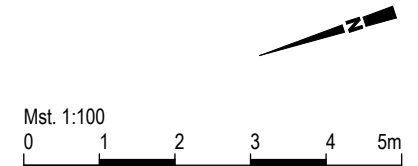
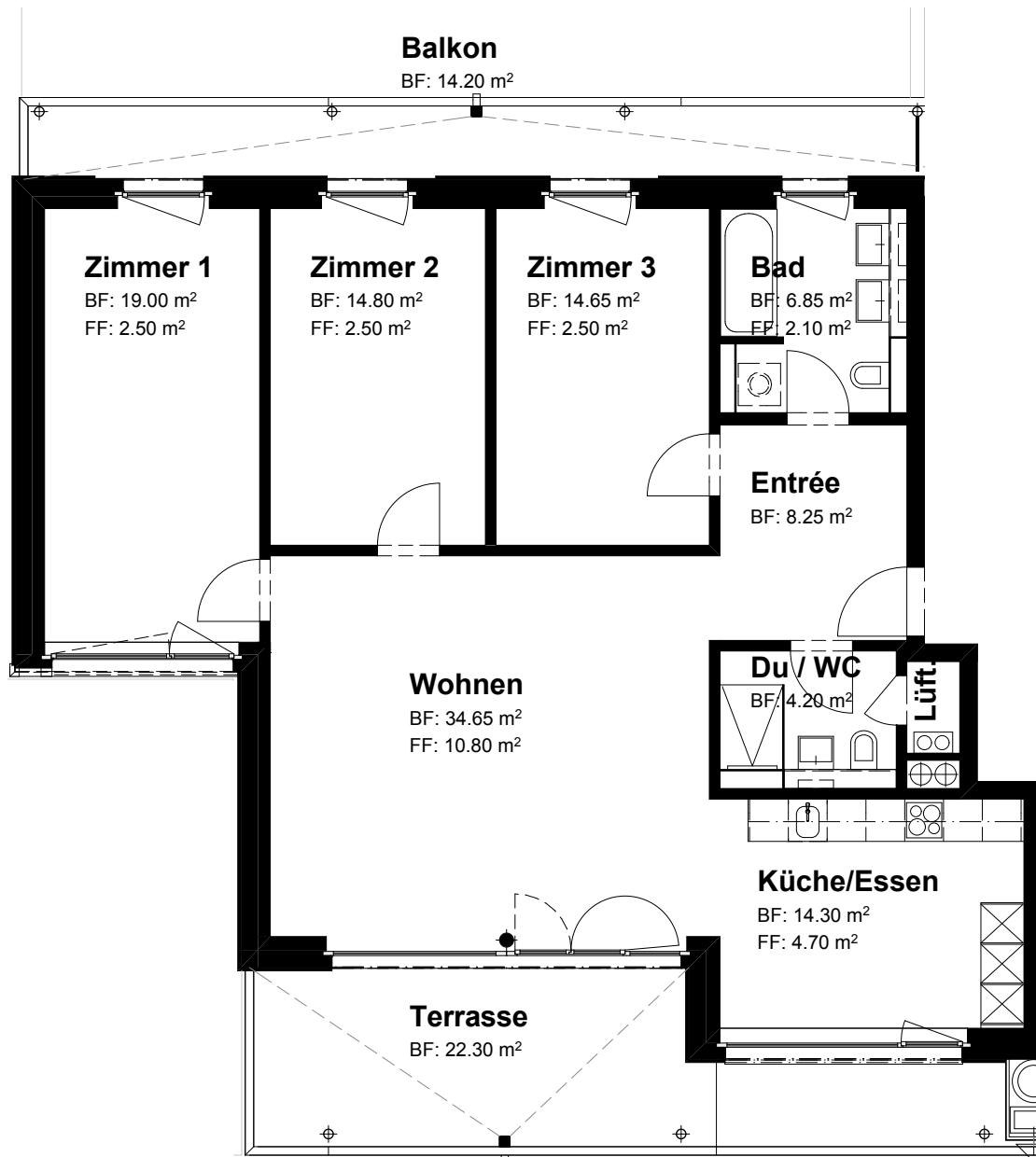
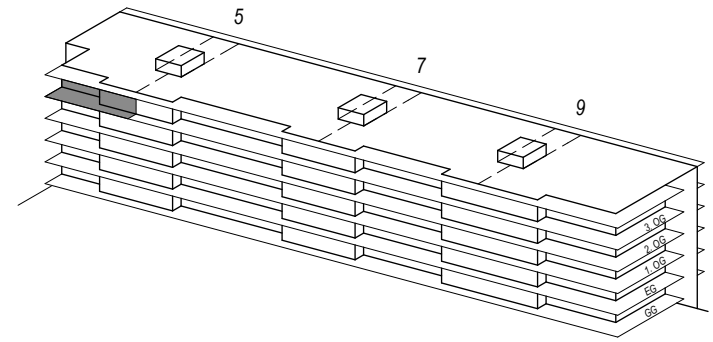

**hwp**ARCHITEKTEN AG

Architekten ETH FH SIA  
Chamerstr. 44 6331 Hünenberg  
t 041 854 70 70 f 041 854 70 60  
info@hwp.ch www.hwp.ch

# Überbauung Roost, Zug

Haus B, Fridbachweg 5,7,9

Gartengeschoss: Wohnung Nr. 0701

4 1/2 - Zimmer, Nettogeschossfläche 133.95 m<sup>2</sup>

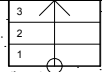
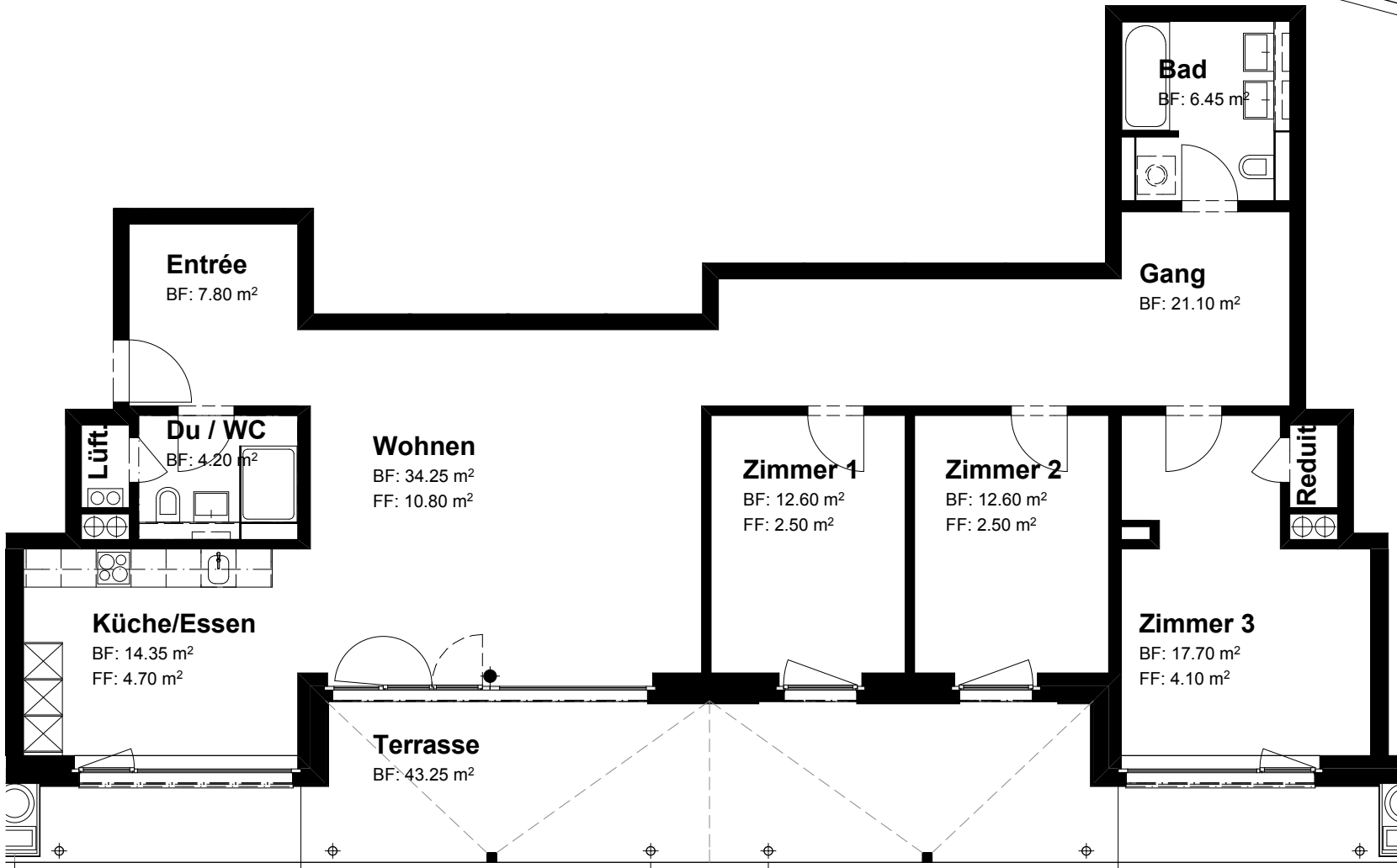
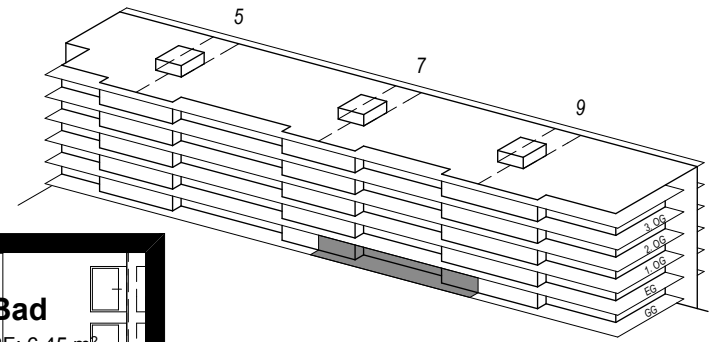

Gartensitzplatz zu Whg. 0701

Mst. 1:100  
0 1 2 3 4 5m

**hwp**ARCHITEKTEN AG

Architekten ETH FH SIA  
Chamerstr. 44 6331 Hünenberg  
t 041 854 70 70 f 041 854 70 60  
info@hwp.ch www.hwp.ch

# Überbauung Roost, Zug

Haus B, Fridbachweg 5,7,9

Erdgeschoss: Wohnung Nr. 0704

4 1/2 - Zimmer, Nettogeschossfläche 116.60 m<sup>2</sup>

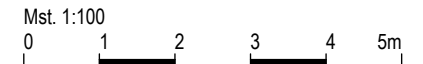
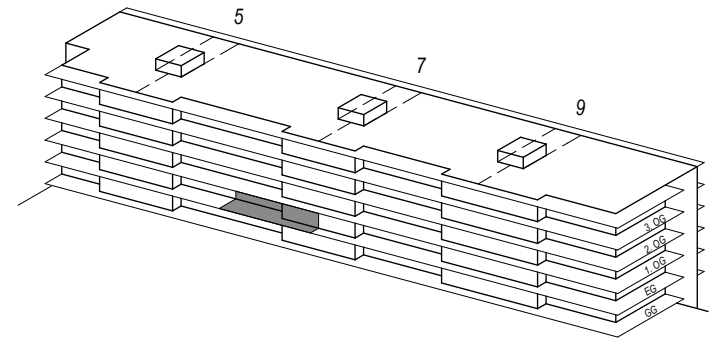
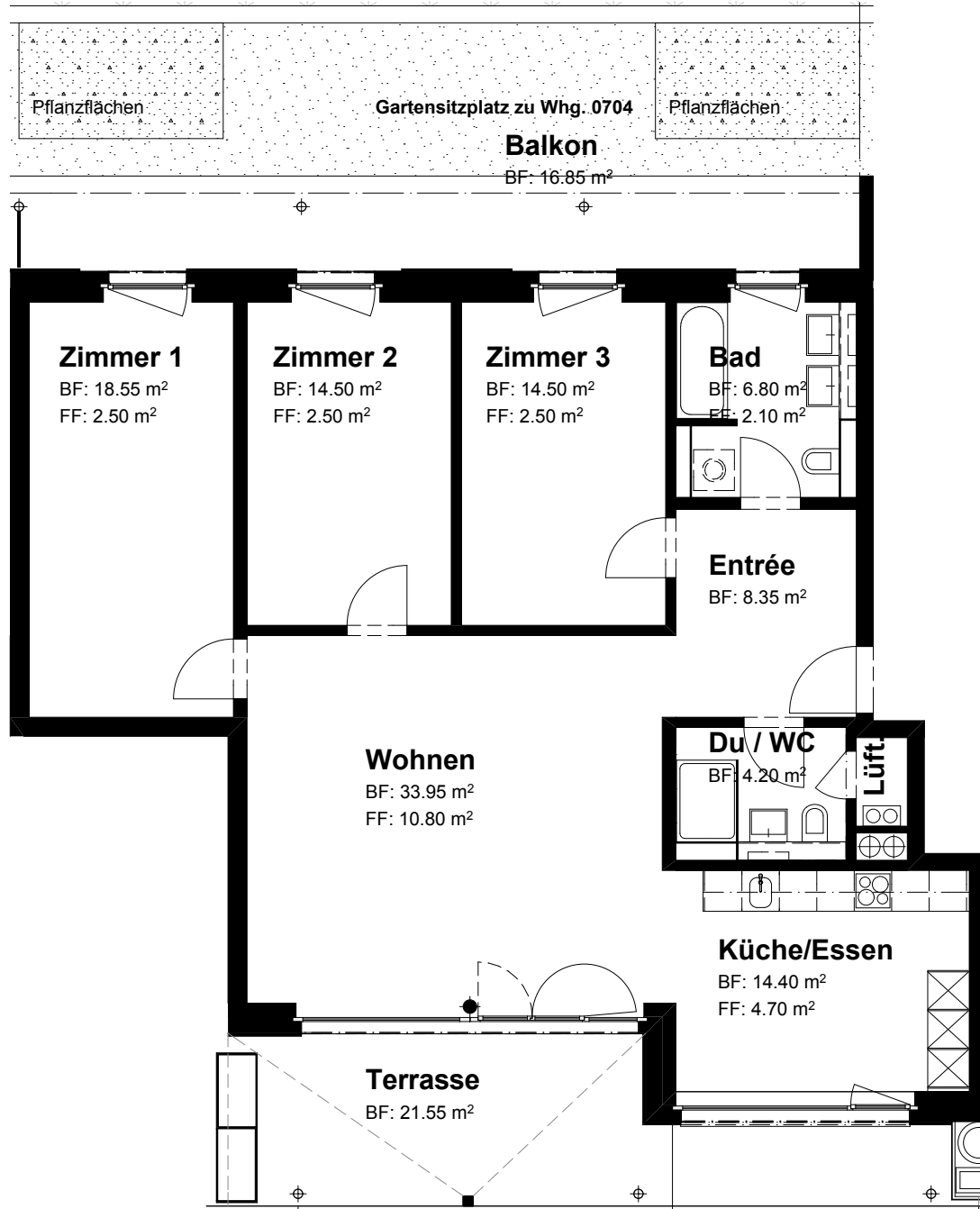

**hwp**ARCHITEKTEN AG

Architekten ETH FH SIA  
Chamerstr. 44 6331 Hünenberg  
t 041 854 70 70 f 041 854 70 60  
info@hwp.ch www.hwp.ch

# Überbauung Roost, Zug

Haus B, Fridbachweg 5,7,9

1. Obergeschoss: Wohnung Nr. 0706

4 1/2 - Zimmer, Nettogeschossfläche 116.75 m<sup>2</sup>

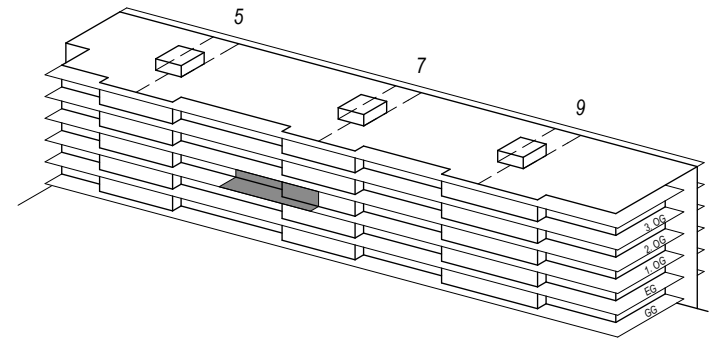
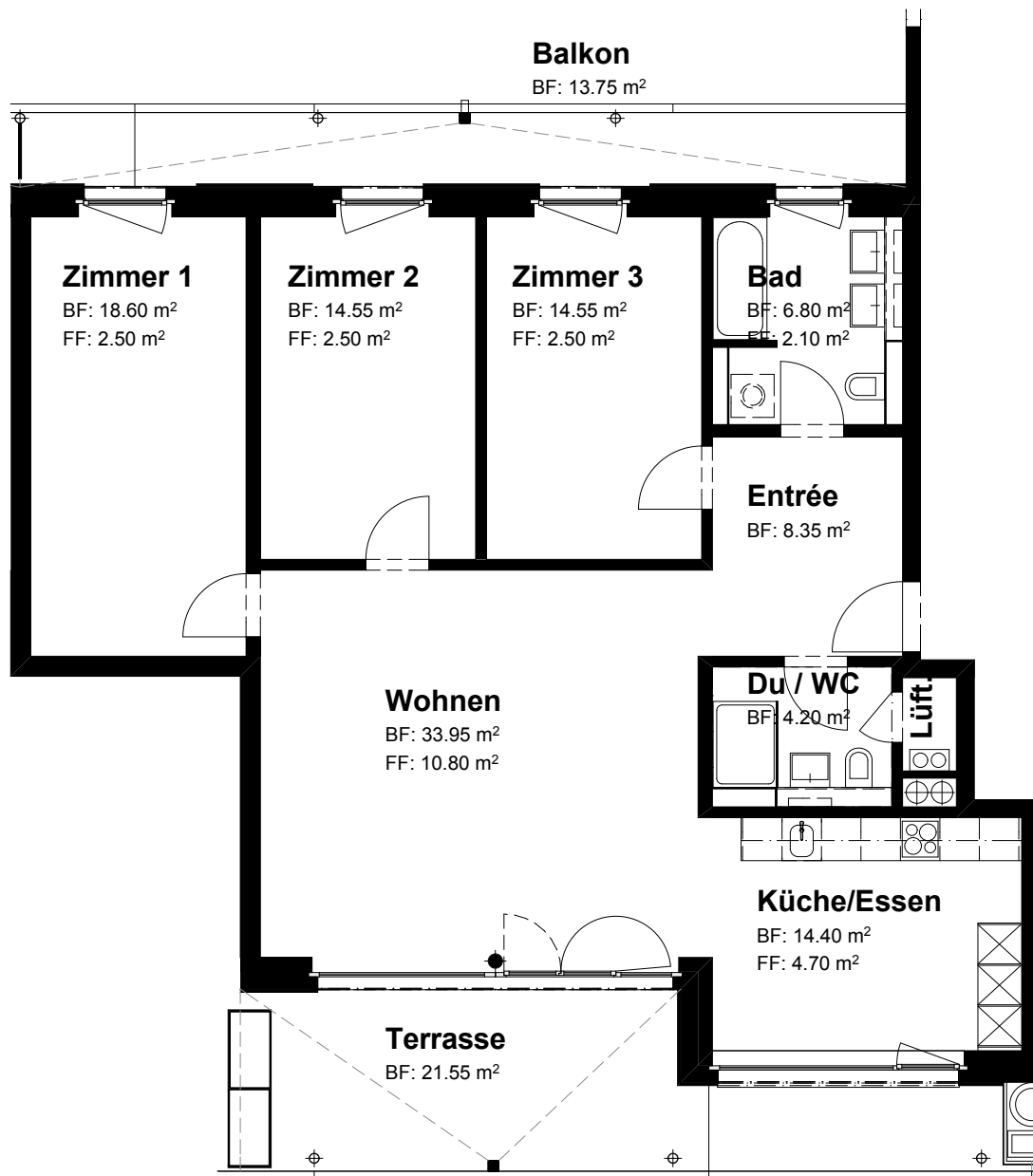

Mst. 1:100



**hwp**ARCHITEKTEN AG

Architekten ETH FH SIA  
Chamerstr. 44 6331 Hünenberg  
t 041 854 70 70 f 041 854 70 60  
info@hwp.ch www.hwp.ch

# Überbauung Roost, Zug

Haus B, Fridbachweg 5,7,9

2. Obergeschoss: Wohnung Nr. 0708

4 1/2 - Zimmer, Nettogeschossfläche 117.05 m<sup>2</sup>

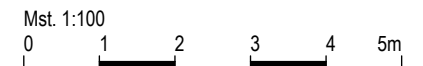
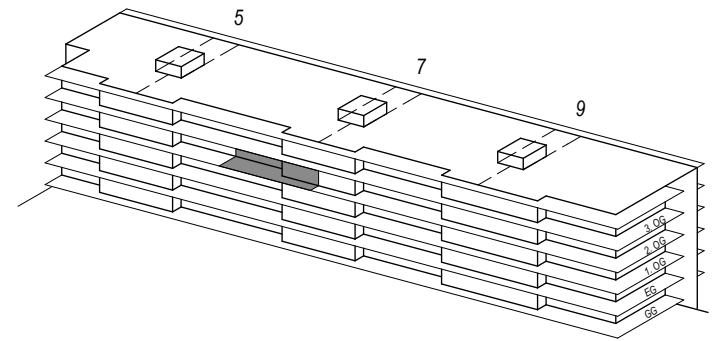
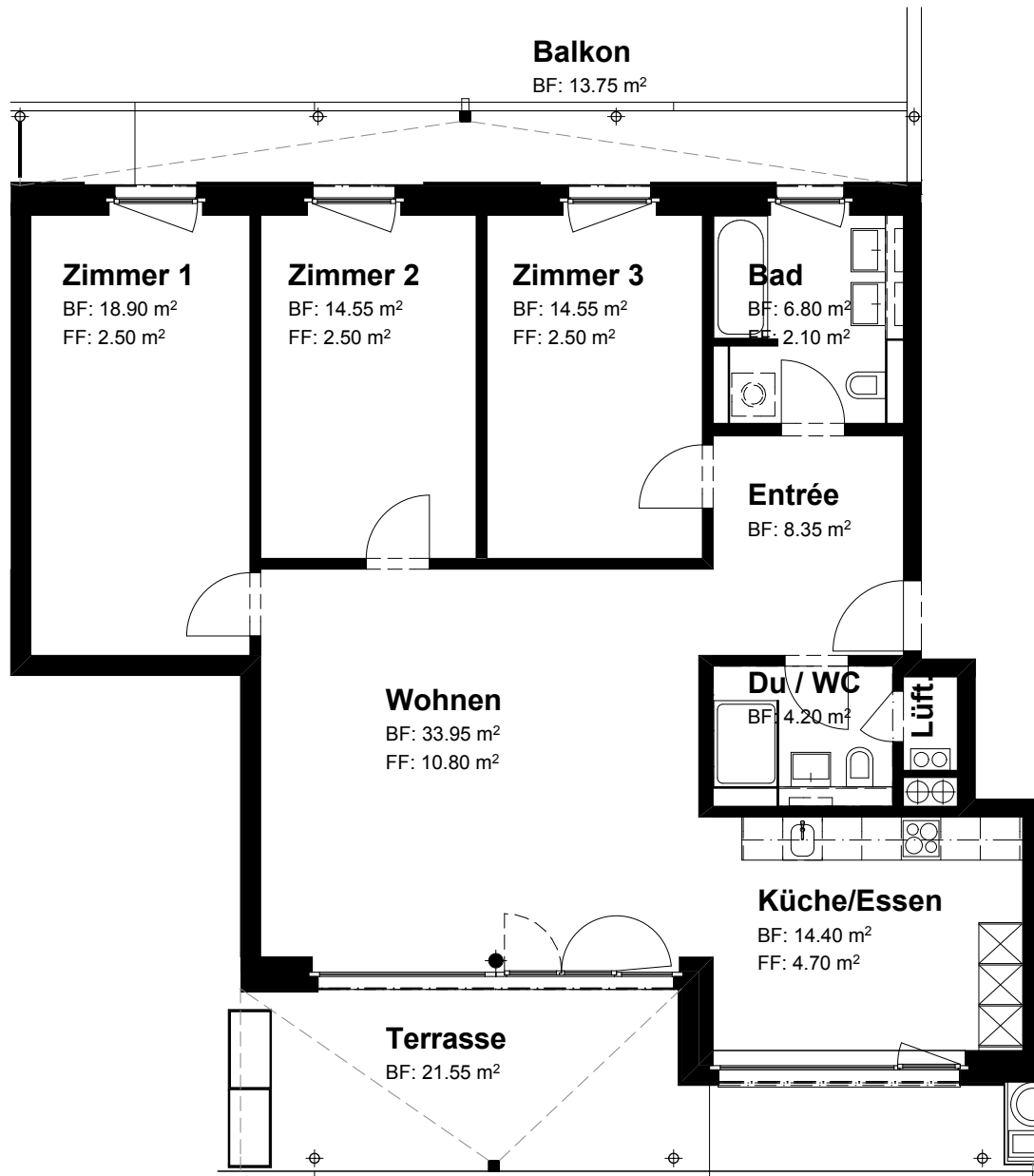

**hwp**ARCHITEKTEN AG

Architekten ETH FH SIA  
Chamerstr. 44 6331 Hünenberg  
t 041 854 70 70 f 041 854 70 60  
info@hwp.ch www.hwp.ch



# Überbauung Roost, Zug

Haus B, Fridbachweg 5,7,9

Dachgeschoss: Wohnung Nr. 0710

4 1/2 - Zimmer, Nettogeschossfläche 117.20 m<sup>2</sup>

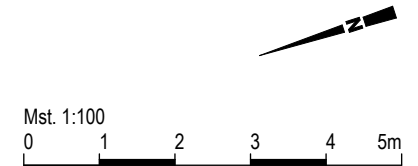
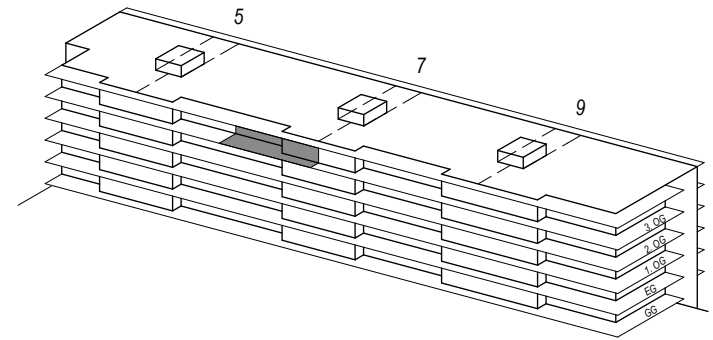
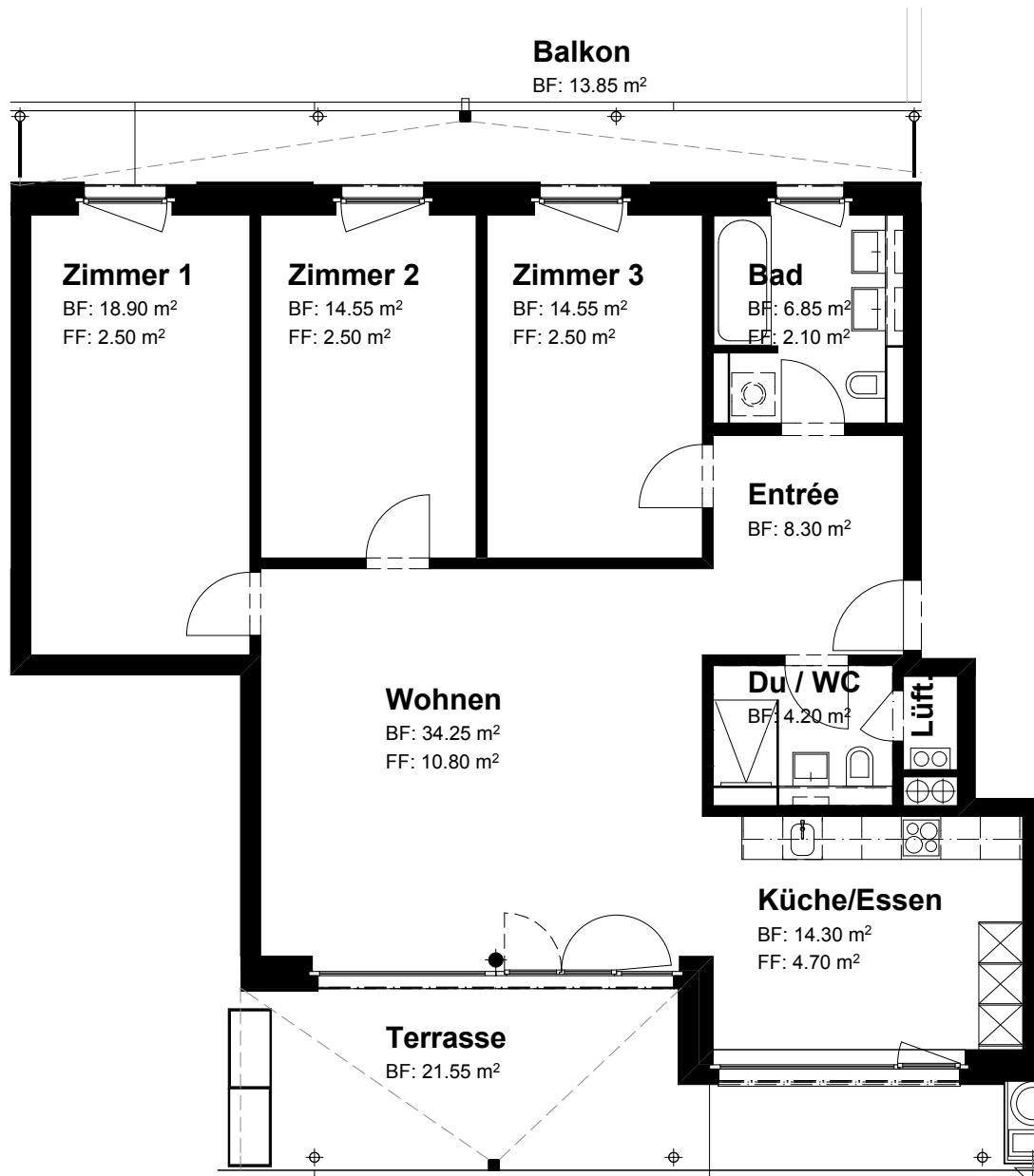

**hwp**ARCHITEKTEN AG

Architekten ETH FH SIA  
Chamerstr. 44 6331 Hünenberg  
t 041 854 70 70 f 041 854 70 60  
info@hwp.ch www.hwp.ch